

**REPORT OF THE STUDY TEAM
ON REORGANISATION OF
EDUCATION DEPARTMENT OF GOVERNMENT OF SIKKIM**



**MINISTRY OF EDUCATION & CULTURE
GOVERNMENT OF INDIA
NEW DELHI**

REPORT OF THE STUDY TEAM
ON REORGANISATION OF
EDUCATION DEPARTMENT OF GOVERNMENT OF SIKKIM

MINISTRY OF EDUCATION & CULTURE
GOVERNMENT OF INDIA
NEW DELHI

OCTOBER, 1981

NIEPA DC



D06924

- 54167

371.2

IND-R

Sub. ... ms Unit,
atic ... Educational
Plan ... m i i ation
IND ... Marg New Delhi-110016

.....6924.....
26.5.92.....

CONTENTS

<u>Chapter</u>	<u>Page</u>
I. INTRODUCTION	1 - 9
II. ORGANISATIONAL SET-UP OF EDUCATION DEPARTMENT	10 - 26
III. PROPOSALS FOR REORGANISATION	27 - 53
IV. OTHER PRIORITY AREAS IN EDUCATION	54 - 61
V. CONCLUSION	62 - 63

ANNEXURES I - IV

CHAPTER - I

INTRODUCTION

1.1 The Study

1.1.1 Soon after Sikkim joined the Indian Union as the 22nd State on May 16, 1975 Shri Veda Prakasha, the then Acting Director of the National Staff College (Now NIEPA) was requested by the Union Ministry of Education to study the educational problems of the State and to make recommendations about the future development of education in Sikkim with special reference to the role that the National Staff College could play in this connection. Shri Veda Prakasha, after making an in-depth study of the educational problems of the State, brought out a report on the State's school system with special reference to its administration entitled 'Extending educational opportunity in Sikkim'. This report contained a number of valuable suggestions and several of them were favourably considered by the State Government for implementation. Programmes and projects were undertaken by the State Government for its educational growth and development. Simultaneously, numerous changes were also brought about in the administrative and supervisory set up of education, but most of these changes were of ad-hoc nature and not based on sound principles of educational management.

1.1.2 In 1980, the State Government again requested the Union Ministry of Education and Culture to depute a team of experts to advise the State in reorganisation of its Education Department at various levels on functional

basis. Accordingly, a study team consisting of the following officers visited the State from June 20 to June 26, 1981:

1. Prof. Moonis Raza
Director,
National Institute of
Educational Planning &
Administration, New Delhi Chairman
2. Miss P.S. Sakuntala,
Deputy Secretary,
Ministry of Education & Culture,
New Delhi Member
3. Shri K. Sethuraman,
Joint Director (Adm),
Directorate of Education,
Delhi Administration, Delhi Member
4. Shri M.M. Kapoor,
Associate Fellow,
National Institute of
Educational Planning &
Administration, New Delhi Member

1.1.3 During its stay of one week, the study team visited a number of educational institutions, met senior officers of the Education and other Departments and also had an opportunity to call on the Governor, Shri Homi J.H. Teleyarkhan and Education Minister, Shri Sanchaman Limboq. The lists of educational institutions visited by the team and the officers with whom the discussions were held is given in the Annexure I to this Report.

1.2 General Scenario

1.2.1 Sikkim is essentially a mountainous State without a flat piece of ground of good size anywhere. The territory

forms the part of the Inner Himalayan range of mountains which part stretches for about 112.70 kilometres in north - south direction and about 64.40 kilometres in its east west trend. Thus the total area of the State is about 7299 sq. kilometres and is divided in the following four districts:

- i) North (Mangan)
- ii) South (Namchi)
- iii) East (Gangtse)
- iv) West (Gyalzing)

1.2.2 The population of the State which was 0.59 lakhs in 1901 has increased to 3.16 lakhs in 1981 i.e. an increase of more than five times during eighty years from 1901 to 1981. It took nearly 40 years to double the population from 0.59 lakhs in 1901 to 1.22 lakhs in 1941. The second doubling took only 33 years. If the present rate of growth of 5% per annum is maintained, then the next doubling may take less than two decades*. The growth rate of Sikkim since 1961 has surpassed the national average and now in 1981 it is practically double the national

* Provisional Population Totals : Paper - 1 of 1981 - Sikkim published by Director of Census Operations, Sikkim - 1981

average. In the following table district-wise selected demographic information has been given for 1971 and 1981:

Selected Demographic Indicators of Sikkim

District/ State/ Country	Population 1981 (In lakhs)	Sex Ratio		Density of population		Decennial growth of rate of population		Percentage of literacy	
		71	81	71	81	71	81	71	81
1	2	3	4	5	6	7	8	9	10
North	0.26	853	787	3	6	33	103	10	29
East	1.39	791	798	90	145	51	62	24	41
South	0.76	912	857	70	101	N.A.	44	15	32
West	0.75	934	906	50	64	N.A.	24	12	23
Sikkim	3.16	863	836	30	44	29	50	18	34
India	6838.1	930	935	177	221	25	25	29	36

1.2.3 It is interesting to note that the sex-ratio in the State has decreased from 863 to 836 in 1981 whereas the national average is showing an increasing trend. Similarly, the rate of growth of literacy has been quite high as compared to the increase at the national level.

1.3 Educational Scenario

1.3.1 The system of education in Sikkim is essentially the same as that in the country as a whole. It, therefore,

shares both its strengths and weaknesses although due to unique local traditions and situations some strengths are highlighted just as some weaknesses get over accentuated.

Systems of School Classes

1.3.2 The system of school classes in Sikkim is as per the following pattern:

Systems of School Classes

<i>School Stage</i>	<i>School Classes</i>	<i>School age groups (years)</i>
<i>Pre-Primary</i>	<i>K. G.</i>	<i>3 - 4</i>
<i>Primary</i>	<i>I - V</i>	<i>5 - 9</i>
<i>Jr. Secondary</i>	<i>VI - VIII</i>	<i>10 - 12</i>
<i>High</i>	<i>IX - X</i>	<i>13 - 14</i>
<i>Higher Secondary</i>	<i>XI - XII</i>	<i>15 - 16/17</i>

1.3.3 The age of entry in this State is 6+. The middle stage of school education is known here as Jr. Secondary Stage. Even in the preparation of plans and budgets, this stage of education is shown as a part of secondary education and not of the elementary education.

Large Scale Expansion

1.3.4 During the last 25 years and particularly after the year 1975 when Sikkim joined the Indian Union as 22nd State the growth and development of education in this State has been remarkable. There were only 88 schools in 1954

which has now increased to 550 in 1981. Similarly the enrolment has also increased from 2500 to 55000 during this period. Since August 14, 1980, education has been made free for all at all levels of school education. In addition, the Government subsidy on text books is given upto 50% at the school level.

In the following table selected educational statistics (for 1975-76, unless otherwise specified) are given for Sikkim viz-a-viz the national position:

Selected Educational Statistics in Sikkim and India

Particulars	Unit	Sikkim	All India
1	2	3	4
i) Number of Institutions	In number	268	641663
ii) Number of Teachers	In thousand	1	3069
iii) Enrolment	In thousand	21	95286
iv) Expenditure	In lakhs	99	210470
v) Percentage share of Sikkim in All India	%		
- Institutions		0.04	100.00
- Teachers		0.03	100.00
- Enrolment		0.02	100.00
- Expenditure		0.05	100.00
vi) Per lakh of population	No.		
- Institutions		116	107
- Teachers		435	511
- Enrolment		9130	15861

1.	2.	3.	4.
<i>vii) Percentage of population served by schooling facilities</i>	%		
- Primary (1 km)		64.34	92.82
- Middle (3 km)		42.30	48.83
- Secondary (8 km)		51.13	17.82
<i>viii) Enrolment ratios</i>	%		
Gross level ER			
I - V class/6-10 years		123.93	82.31
VI-VIII class/11-13 years		27.30	36.92
<i>ix) Percentage of girls enrolment</i>	%		
- Primary Stage		39	39
- Middle Stage		33	33
- Secondary Stage		31	29
<i>x) Teacher pupil ratio</i>	Ratio		
- Primary Stage		25	41
- Middle Stage		13	25
- Secondary Stage		8	18
<i>xi) Percentage of single teacher school</i>	%	15	35
<i>xii) Average annual expenditure per pupil</i>	Rs.		
- Primary schools		280	96
- Middle schools		126	144
- Secondary schools		466	257

1.	2.	3.	4.
xiii) Per capita education expenses	Rs.	43	35
xiv) Share of educational budget to total State budget (Revenue) (1978-79)	%	12	26
xv) Sector-wise education expenditure (1978-79)	%		
- Primary education		28	47
- Secondary education		61	32
- Adult education		3	0.4
- University education		2	13
- Technical education		-	3
- Others education		6	4

1.3.6 The latest selected educational statistics are given here for 1981-82:

i) Number of Schools

- Pre-Primary	100
- Primary	334
- Middle	48
- Secondary	31
- Higher Secondary	9
Total	<u>552</u>

Source: Education in India (1975-76) published by the Ministry of Education.

ii) Enrolment

- Pre-Primary Stage	3006
- Primary Stage	45271
- Middle Stage	8912
- Secondary Stage	2187
- Higher Secondary	788
	<hr/>
Total	66164
	<hr/>

iii) Number of Teachers

- Pre-Primary Centres	100
- Primary Schools	1220
- Middle Schools	496
- Secondary Schools	581
- Higher Secondary Schools	199
	<hr/>
Total	2596
	<hr/>

1.3.7 There is only one college of General Education and one Industrial Training Institute. Recently one Law College has also been started.

CHAPTER-II

ORGANISATIONAL SET-UP OF EDUCATION DEPARTMENT - PROBLEMS AND ISSUES

2.1 Present Set-up

2.1.1 The present administrative set-up of the Education Department of the State is based on the overall reorganisation of the Department which was undertaken in 1975. Since then some significant developments of far reaching importance have also taken place e.g. efforts to separate the agencies of Directorate and Secretariat in education; creation of one more layer of administration between State and the District i.e. Regional Deputy Directors; passing of the Sikkim Board of School Education Act, 1978.

2.1.2 The existing Directorate of Education is concerned with only school education and not with technical and higher education.

2.1.3 An administrative chart containing details of pay scales and strength of various posts is given in Annexure-II of this Report. The existing set-up can be divided into three levels:

- a) District level,
- b) Regional level; and
- c) State level.

District Level

2.1.4 In each of the four Districts of the State, there is one District Education Officer. He is of the rank of Asstt. Director Education in the pay scale of Rs.660-1400 and is incharge of schools upto primary and junior high (middle)levels. The strength and set-up of the District Education Office varies from District to District. However, organisational set-up of a typical office of the D.E.O. is shown in the following diagram:

District Education Officer

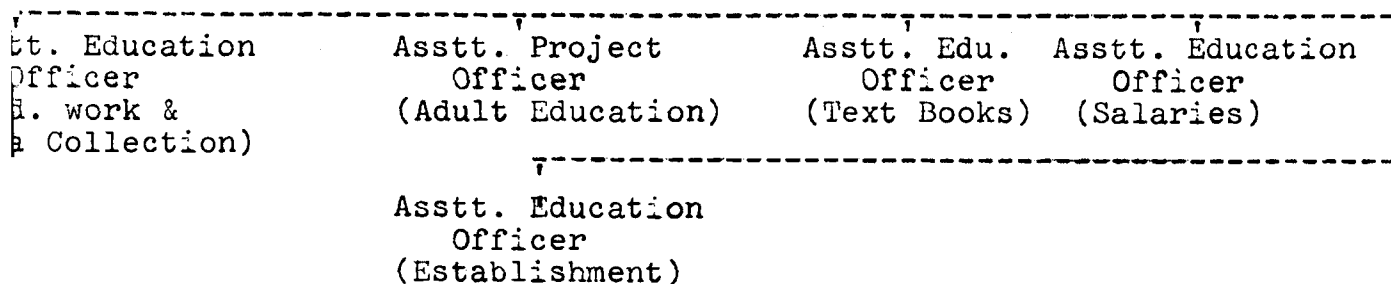

2.1.5 The main features of the district level set-up are:

- i) The set-up varies from District to District and from time to time in a district. In most of the cases, the work of Asstt. Education Officers is either not clearly defined or defined on an ad-hoc basis. Some time they also assist D.E.O. in supervision and inspection of primary schools. It may be mentioned that two additional posts of Asstt. Education Officers were provided to each District-one for promotion of science education and other for social science education.
- ii) The D.E.O. is Class-II gazetted Officer and is of the rank of Assistant Directors, Post-Graduate Teachers in Higher Secondary Schools and Headmasters of High Schools.

- iii) About 50% of the time of D.E.O. is spent on budget and accounts matters particularly pertaining to drawing and disbursement of monthly salaries of the staff in the district. About 30% of the time is devoted to establishment cases and hardly 20% of time is left for academic matters.
- iv) Assuming that responsibility of inspecting Junior High Schools (Middle School) is that of D.E.O. and of pre-pry. & Primary Schools is that of A.E.Os, the existing workload in terms of number of schools per officer works out to be as under:

Number of Schools per D.E.O. & A.E.O.

District	Number of		Number of				No. of Schools per			
	D.E.O.	AEOs	Total	Jr.High Schools	Pry. Schools	Pre-Pry Schools	Total	DEO	AEO	Officer
1	2	3	4	5	6	7	8	9	10	11
North	1	2	3	6	34	26	68	8	30	23
South	1	3	4	15	89	5	109	15	31	27
East	1	4	5	12	121	64	197	12	46	39
West	1	3	4	13	90	5	108	13	32	36

- v) To meet the day to day contingent expenses, an imprest amount of Rs.500/- is kept at the disposal of the D.E.O.
- vi) Administrative powers vested in D.E.O. in respect of primary and junior high schools comprise of:
- Appointment of substitute teachers for a maximum period of two months at a time;
 - Transfers of teachers within a district;
 - Release of all increments of teachers except in case of efficiency bar and the first increment; and
 - Sanction of leaves of all types.

- vii) Like other States of the country, there is no inspection or supervision agency below the district level. However, the system of school complexes was introduced in 1976 for primary schools with the following type of organisational structure:

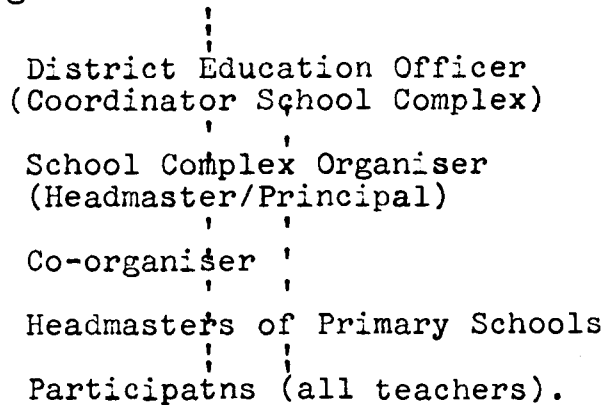

The primary schools are attached to the nearest Junior High School or High or Higher Secondary School.* Various programmes and activities which were suggested for school complexes, among others, included inter-school visits, monthly meetings, circulatory library & supervisory visits. The number of school complexes in each district at present is:

<u>District</u>	<u>No. of School Complexes</u>
North	8
South	18
East	28
West	12

*Ref. Circular No.23/Edn./76 dated Oct.26, 1976

- viii) The total staff strength including ministerial and Class IV staff in various districts is as under:

District	Number of						Total
	DEO	AEO	APO	UDC	LDC	Driver/Peon	
1	2	3	4	5	6	7	8
North	1	-	1		3	2	7
South	1	3	1	1	2	2	10
East	1	4	1	1	4	1	12
West	1	3	1	1	2	3	11

- ix) Every D.E.O. has a jeep which was purchased in 1976.
- x) Though the D.E.Os are the drawing and disbursing officers, but they can exercise this power in respect of salary bills only as there/no district-wise budget allocations. are

Regional Level

2.1.6 It is only recently that this level of educational administration between District & State has been introduced in order to "ensure continuous inspection and supervision of all types of schools and district education officer".* The State has been divided in two educational zones, one comprising North and East Districts and the other South & West Districts. An Officer of the rank of Dy. Director of Education has been made incharge of each Zone as per following structure:

Zonal Deputy Directors(Two)

North & East Districts i) 19 High Schools ii) Two DEOs	South & West Districts i) 12 High Schools ii) Two DEOs
--	--

*Annual Plan of State Education Deptt. for 1981-82

2.1.7 In each office there is one L.D.C., one Peon and one Driver. Both the officers have jeeps at their disposal. The administrative and financial powers of these two zonal Dy. Directors have not yet been precisely defined.

State Level:

2.1.8 The administrative set-up of school education at the State Level can be explained under three heads:

- i) Secretariat of Education;
- ii) Directorate of Education; and
- iii) State Institute of Education.

i) Secretariat of Education:

2.1.9. Till recently, the Director of Education was also ex-officio Education Secretary and the functions of secretariat were used to be performed by the Directorate of Education. Now there is a separate Education Secretary who in addition to Education, holds charge of other Department(s) also. For want of clear demarcations of functions between secretariat and Directorate, the new system has yet to prove its worth.

ii) Directorate of Education:

2.1.10 The Director of Education, who is a 'Major Head of Department', has to look after the following Divisions/sections with the assistance of one Joint Director:

- a) Planning and Statistics Division
- b) Establishment Division
- c) Scholarships and Examinations
- d) Adult and Non-formal Education Division
- e) Languages Section
- f) Personnel Section
- g) Accounts Branch
- h) Sports, Youth Welfare and NCC Branch
- i) State Institute of Education.

2.1.11 In addition to the above Division/Branches, the Directorate is also responsible for inspection and supervision of Higher Secondary Schools, Zonal Dy. Directors of Education and District Education. All officers in the above Division/Branch, except the last three (i.e. from g to i) are headed by the officers of the rank of Dy. Directors of Education. The last three branches are under the charge of officers of the rank of Asstt. Directors of Education. The other main features of the set-up of the Directorate of Education are:

- a) The duties, responsibilities and functions of various Division & Branches of the Directorate have not been clearly defined. As such, there is lot of confusion, duplication, overlapping, and lack of coordination in the functioning of the Directorate of Education.
- b) Except Asstt. Education Officers, all other officers are in the gazetted rank. AEOs are in the pay scale of graduate teachers and Headmasters of Jr. High Schools (middle schools) In the following statement, a comparative study has been made between the pay scale of the officers of the Directorate of Education and other selected Departments of the State Government:-

Comparative Statement of Pay Scales

Pay Scale	Names of Posts	
	Education Department	Selected other Departments
1	2	3
1350-2400	Director	Director, Medical Deptt.
1200-2000	Joint Director	-Joint Secretary to Govt., -Joint Director(Health). -Superintendent Engg.
900-1800	-Dy. Director -Principals of Hr. Secondary Schools	-Dy. Secretary to Govt., -Dy. Commissioner -Principal, I.T.I. -Executive Engineers.
660-1400	-Asstt. Director -Distt. Education Officer -D.S.D.(Edu) -Accounts Officer -Text Book Officers -Headmasters of High Schools -Post Graduate Teachers of Hr. Sec. Schools. -Headlama of aHr.Sec.School having 20 years of experience.	-Under Secretary to Govt. -Asstt. Commissioner -Distt. Industries Officer -Asstt. Engg. -Asstt.Director(Health)

- c) In addition to the Director and Joint Director of Education, the number of officers in various Divisions and Branches is as given below:-

Number of Officers in the Directorate of Education

Division/ Branch	Number of Officers			Total
	Dy. Director	Asstt. Director/ Accounts Officer	Asstt. Edu. Officer	
1	2	3	4	5
1. Planning	1	2	1	4
2. Establishment	1	1	1	3
3. Scholarships & Examinations	1	-	1	2
4. Adult & Non-formal Education	1	1	-	2
5. Languages	1	4	4	9
6. Personnel Sections	1	1	-	2
7. Accounts Branch	-	2	-	2
8. Sports & Youth Welfare & NCC	-	1	4	5
9. State Institute of Education	-	4	5	9
Total	6	16	16	38

- d) The supporting staff in various Divisions and Branches of the Directorate is, in most of the cases, of UDC and its lower levels. The grade-wise and post-wise position of ministerial and Class IV staff is given in the following table:

Number of Ministerial & Class IV Posts in the Directorate of Education

Post	Scale of pay	Number of posts in the Division of									Total
		Plg. & Sts.	Est- ab- lish- ment	Sch. & Exam.	Adult Edu.	Lang- uage	Per- so- nnel	Accounts	Sports & Youth Welfare	SIE	
1	2	3	4	5	6	7	8	9	10	11	12
Office Superintendent/ Sr. Accountant/Text book artist	510-900	-	2	-	-	1	-	-	-	-	3
Establishment asst/ cashier/ Ad Asstt	450-800	-	1	-	-	-	-	1	-	-	2
DC/Sts. asst/ P	410-700	3	4	-	1	-	1	3	1	1	14
Asst/ clerks	380-550	3	7	2	1	1	-	6	6	3	29
Over/ stry/Head Peon/ patcher/ ary ndent	340-500	1	4	-	1	-	-	-	-	1	7
Ar	300-380	2	3	1	1	3	-	2	5	2	19
		9	21	3	4	5	1	12	12	7	74

iii) State Institute of Education and Languages Section

2.1.12 The State Institute of Education and the Languages Section form part of Directorate of Education like its other Divisions and Branches as mentioned above.

2.1.13 The State Institute of Education is not only responsible for inservice training courses but also for pre-service regular training courses for teachers. Vocational education, Educational Technology and UNICEF Project also form part of the S.I.E.

The existing set-up of the S.I.E. is shown below:

State Institute of Education

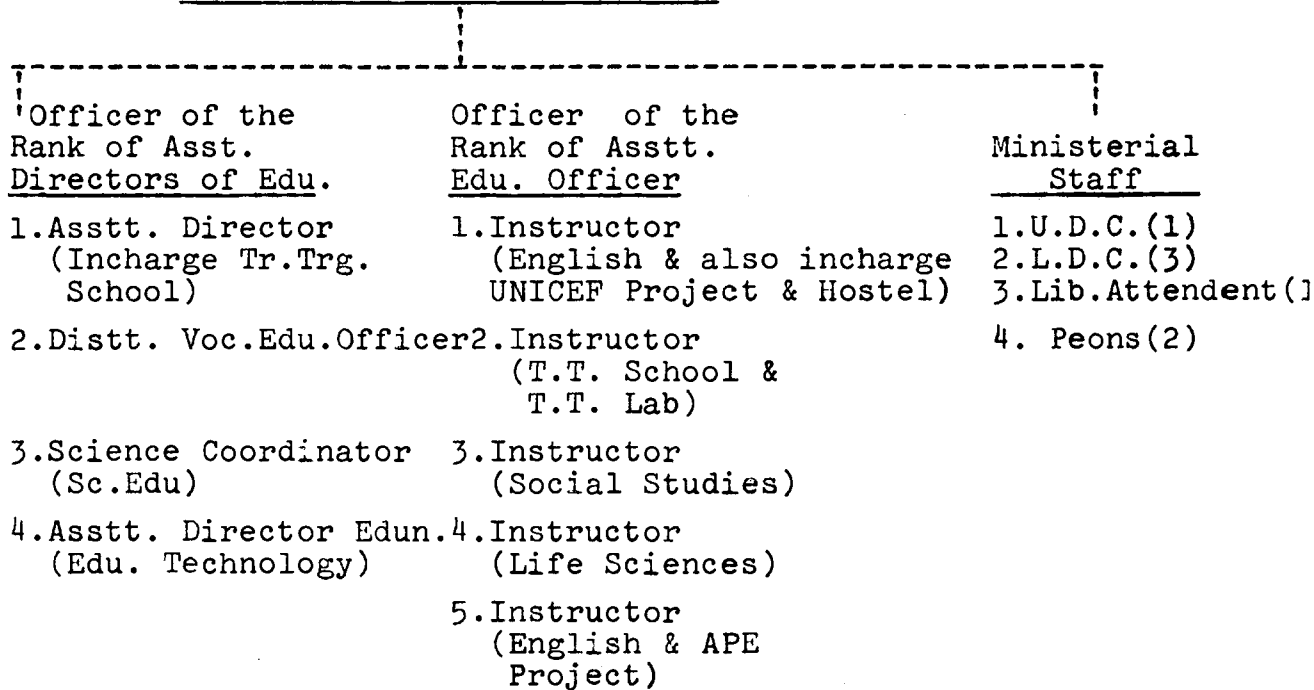

2.1.14 The Language Section is responsible for inspection and supervision of text books; appointment, training and transfer of language teachers; etc. Its set up is as under:

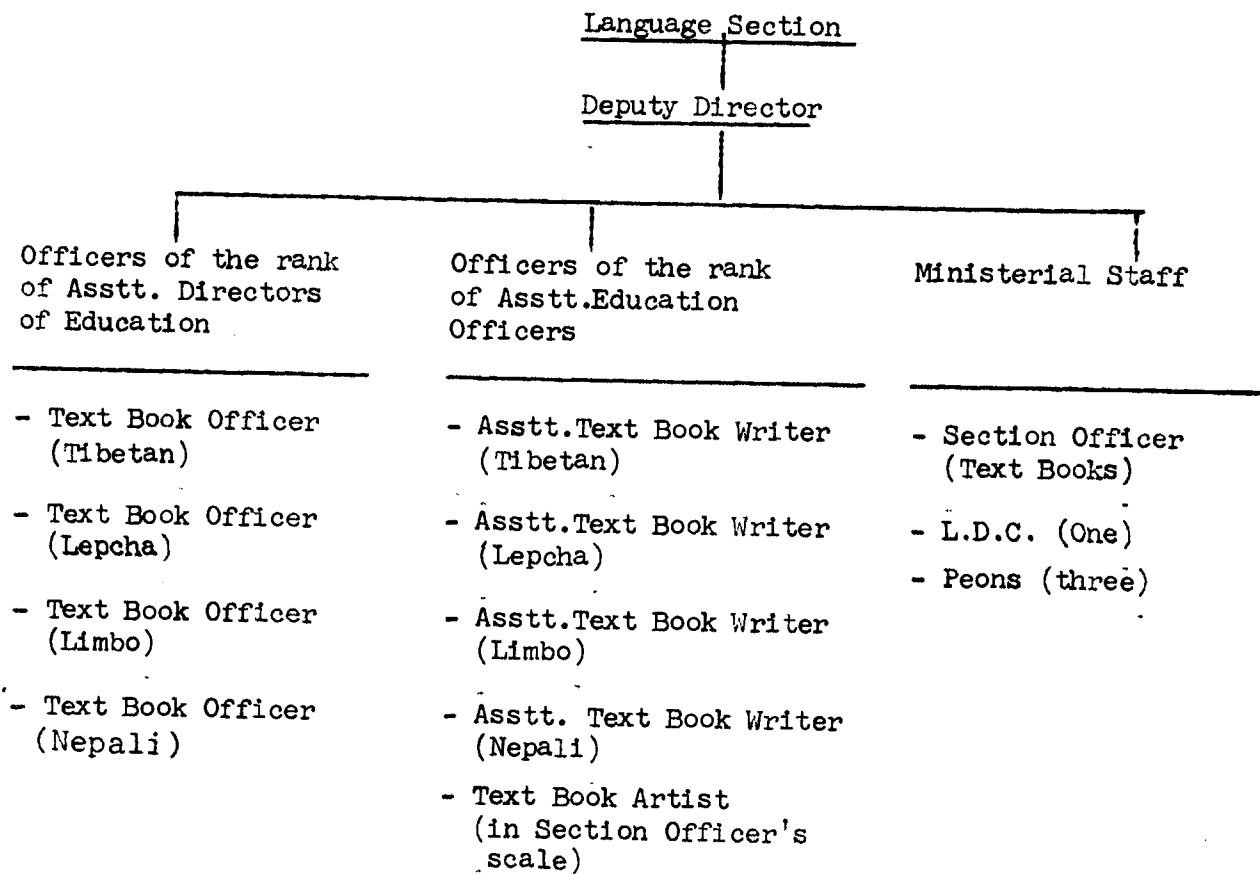

2.1.15 Similarly, the conduct of examinations in schools is also a function of the Directorate of Education.

2.1.16 At present both these sections are housed in a very small building.

2.2 Problems and Issues

Several factors can be identified which are responsible for creating various difficulties and bottlenecks in the existing administrative set-up of the Education Department of the State at different levels. Some of these factors are:

2.2.1. Inadequate Staff:

While the workload has increased enormously but the staff expansion in the Education Department has not kept pace with the demands of the situation. The Directorate of Education is, at present, rather poorly staffed, particularly at the officers' level and still more poorly organised. Some of the very important Divisions/Branches are not even headed by officers of the rank of Dy. Director of Education e.g. S.I.E., Accounts Branch & Sports & Youth Welfare Branch. The post of Asstt. Education Officer is of the rank of headmaster of a middle school i.e. trained graduate and neither falls under the category of officers nor ministerial staff. Offices of most of the Divisions/Branches are under the charge of officials of the rank of U.D.C. instead of Head Assistants or office superintendents.

At the District level, there is only one officer and that is the Distt. Education Officer himself. There are no norms for creation of additional supervisory posts. Below the district level, there is no supervisory staff e.g. Block or Tehsil Education Officers. As already mentioned, the D.E.O has to spend about 70% of his time on matters pertaining to administration and accounts.

2.2.2. Ad-hocism

For want of clearly defined rules and regulations governing the recruitment, promotion and transfer of officers of the Education Department, all decisions are taken on ad-hoc basis. Even in case of delegations of powers and distribution of work among various divisions and branches of the Directorate, there are no clear guidelines. As such there is overlapping and duplication of work and an element of confusion and delay in the method of approach even in disposal of routine cases. Some posts continue to remain vacant over a long period even at the cost of office work. Some officers in the office are overworked whereas some have not even adequate work. Proper scrutiny of cases or schemes is not done in the office. Generally the officers do not work according to a well planned schedule but according to day to day demands of work.

2.2.3. Secretariat in Directorate of Education

As mentioned earlier the Director of Education used to function as ex-officio Education Secretary and there was no separate Education Secretary. Presently the State has an Education Secretary and a Director of Education. The practice in the States vary. In some States there are separate Secretariat and in others the Director of Education is designated the ex-officio Secretary of the State Govt. It is at any rate necessary to have a clear demarcation of work and responsibility between the Secretary and Director.

2.2.4. Centralization of Authority

Whereas the Directorate has grown into a huge entity, there has not been any progressive delegation of powers to the district level for taking quicker decisions at least on routine matters. There is no district level allocations of budget and the D.E.O. is a drawing and disbursement authority in matters pertaining to salaries only. For all other programmes & schemes, authority has been centralised in the Director's office. Director of Education is so heavily engrossed in personnel administration and other day-to-day staff matters that little time is left for him to perform his principal responsibility of providing leadership to his District Officers for any qualitative improvement of educational activities.

2.2.5 D.E.O. as a Weakest Link

District Education Officer of this State is just like a Block Education Officer of other States and is in-charge of primary and middle (Jr.High) Schools only. He is of the rank of Head of a High School. His office, barring a few honourable exceptions, generally presents a picture of inadequate and inefficient ministerial staff at the lowest rung and overworked or inept officers at the top, all of them combining to present a picture of redtapism, delay and inefficiency.

2.2.6. Problems in distribution of pay

As there are no branches of State Treasury at the District level, D.E.O. has to waste more than half of his time in drawing and disbursement of salaries to the staff of the schools coming under his jurisdiction. It is said that the present procedure creates a lot of paper work for D.E.O. and deprives him of a good part his time required for his main function of guiding and supervising the schools.

2.2.7 Role of Zonal Dy. Directors of Education

The agency of Zonal Deputy Directors has been created without going deep into needs and functions of this agency in the field, to supervise high schools and two D.E.Os. Whether existence of this agency is required needs to be given a second thought, particularly in a small State like Sikkim.

2.2.8 Lack of Norm, Rules and Regulations of Educational Services

There are no norms, rules or regulations for maintenance and development of educational services in the State e.g. recognitions and grant-in-aid rules, norm for opening and upgrading of schools and provision of staff therein, education code, private institutions regulations act, rules for recruitment, promotion, training and transfers of teaching and non-teaching staff etc. It is interesting to note that schools are first opened by the local community without any plan or permission of the Education Department and, thereafter, teachers in that school are to be provided by the Department and later on schools are taken over by the Government. This system, for want of any rules and regulation, is giving rise to a number of mal-practices and needs to be immediately regulated.

2.2.9 Equipment & Maintenance

There is also the dearth of modern office equipments in almost all the offices under the Department of Education. Only very few duplicating machines, typewriters and filing cabinets are available. Even the few available typewriters were found to be not in good shape and need proper repairs and better maintenance. Similarly, most of the schools

are also ill equipped in respect of furniture and other teaching aids. Non-availability of adequate funds and difficulties of transportation to far flung areas have been attributed to be the cause of the ill-equipment.

2.2.10 Lack of Decentralised System of Planning, Monitoring and Information System

There is a system of centralised planning at the State level and even at that level there is no long-term perspective plan for educational development of the State. Systems of monitoring and management information are yet to be introduced in the State. There are a number of forms, which are used for collection of data from the field separately by planning, statistics & administrative agencies. Even these ill-designed forms are changed from time to time.

2.2.11 Other Problems

In addition to the aforementioned problems and administrative bottlenecks, the present set-up is also not able to meet and face the challenges of changing educational needs and requirements.

For example:

- a) There is no effective agency to organise, implement and monitor the programmes of universalisation of elementary education in the field.
- b) The Government constructed buildings are maintained by the P.W.D., but there is no agency within the Education Department that could take care of construction and maintenance of buildings through community participation.

- c) State Institute of Education is very poorly staffed and equipped and accommodated in a shabby building. It needs to be totally revamped for improvement of teacher education programme in the State. The same is the case with Youth Welfare and Sports Wing and Vocational Education Programmes.
- d) There is no effective coordination between Education and Other Departments particularly department dealing with Technical Education i.e, I.T.I.

CHAPTER - III

PROPOSALS FOR REORGANISATION

- 3.1.1 *The need for a change in the existing set-up is thus obvious. The need for change has become all the more imperative because of the demands of a welfare State which more than anything else signifies speedy and efficient transaction of Government business, speedy and effective redress of individual complaints or public grievances and an impartial and honest administration always willing to respond to public opinion and needs.*
- 3.1.2 *The new set-up which is being proposed here, will have the following main features:*
- a) *District will be the strong working unit of educational administration and planning and D.E.O will be responsible for work relating to all types of schools upto High School level.*
 - b) *Instead of Zonal Dy. Directors of Education, there will be Zonal Education Officers of the rank of Assistant Director of Education especially work for universalisation of elementary education under the overall guidance of D.E.O.*
 - c) *The State Institute of Education will be completely overhauled so as to become an independent organ of the Education Department, for improvement of programmes of teacher education.*

- d) *The Directorate of Education will be completely reorganised. In addition to strengthening of Planning and Statistics Unit, some new units of appropriate size will have to be created to look after new programmes of educational development e.g. Works Branch.*
 - e) *The Education Secretariat will be made responsible for sector of Higher and Technical Education.*
 - f) *The posts of Assistant Education Officers which are in the pay scale of Rs.550-1100 will be abolished and their place will be taken over either by the Assistant Directors of Education or Section Officers.*
 - g) *The work of subject-specialists will be taken over by the subject teachers of the school complex in a district.*
- 3.1.3 *Accordingly, the Study Team has evolved a set of recommendations which are enumerated in the succeeding paragraphs for organisational re-construction of the Education Department.*

3.2 Strengthening of District Education Offices

- 3.2.1 *The establishment of a strong district unit envisages a District Education Officer at the top to be assisted by an adequate number of Deputy District Education Officers at the Headquarter and proportionate number of Zonal Education Officers in the field depending upon the number of primary and middle schools. While DEOs office would look after all types of schools within its jurisdiction (except Higher Secondary Schools), the D.E.O. would be responsible for the inspection of High Schools only. As a matter of fact the Higher Secondary Schools should also come under his jurisdiction but the pay scale of Principal of a Higher Secondary*

School is already equivalent to that of a Deputy Director of Education, and administratively it will not be feasible to put these schools under D.E.O.

- 3.2.2 *The District Education Officer in the new set-up will be 'King-pin' and will be head of a strong district unit of educational administration. His triple functions would be inspection, supervision and implementation of Government's policy in the field. Such an officer, if he is to discharge his multifarious functions with confidence and ease, must have adequate status. His post should be, therefore, in no way less than that of the existing Deputy Director of Education. It means that the pay scale of the existing four posts of D.E.Os will have to be raised from Rs.660-1400 to that of Rs.900-1800.*
- 3.2.3 *As the D.E.O. is to be the local head of the Education Department, therefore, he should be a man of high academic qualifications and a seasoned educationist. Since he is to control a huge establishment, he must have a flair for administration and a sound knowledge of working of the Department.*
- 3.2.4 *The organogram given on the next page indicates the proposed set-up of the D.E.O's office:*

District Education Officer
(Proposed Set-up)

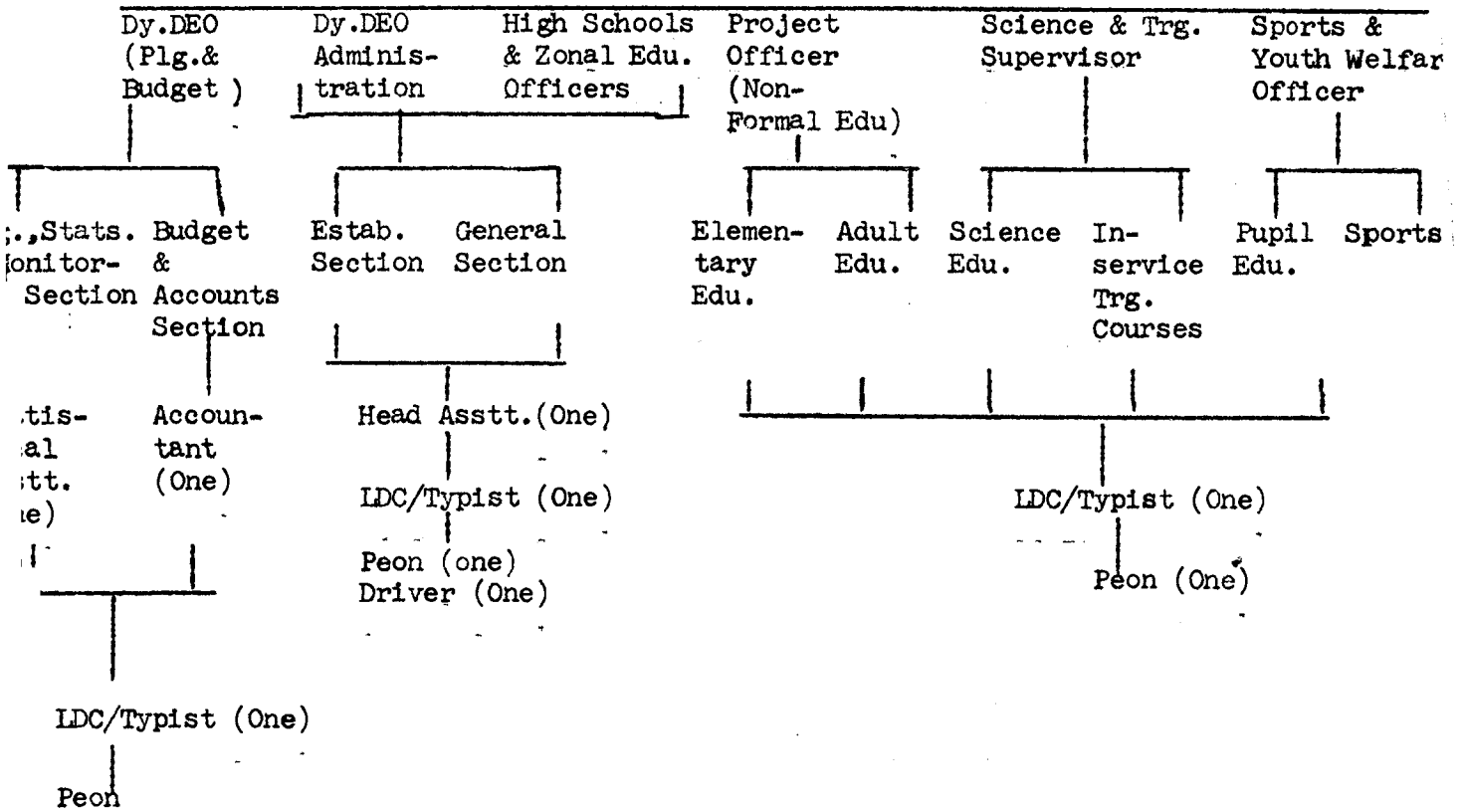

3.2.5 In the above charge, the minimum number of posts for each of the District have been shown. All the officers in the D.E.O's office i.e. Dy. D.E.O., Project Officer, Science & Trg. Supervisor and Sports and Youth Welfare Officer, should be of the rank of Assistant Director of Education in the pay scale of Rs.660-1400. One additional post of Dy. D.E.O. should be created for every group of 30 to 35 High Schools so as to assist the D.E.O. in supervision of high schools.

3.2.6 The minimum ministerial and class IV staff of a district should consist of:

Statistical Assistant	- One
Accountant	- One
Head Assistant	- One
LDC/Typists	- Three
Peons	- Three

3.3 Zonal Education Officer

3.3.1 This is a new supervisory post which is being proposed particularly for primary and middle (Jr. High) Schools. The main functions of Z.E.O. are inspection, supervision, establishment of schools upto middle level and planning and implementation of various programmes for universalisation of elementary education. Z.E.O's, who should be of the rank of Assistant Directors of Education, and be made directly incharge of the following types of institutions:

- a) Pre-primary, primary and middle schools;
- b) Non-formal education centres of adult and elementary education
- c) School complex organisers

3.3.2 So far as creation of additional posts of Z.E.O. are concerned, the following norms are suggested:

For every 40 points - One additional post of Z.E.O

The points should be counted on the basis of weightage to be given to different types of schools as under:

<u>Type of School</u>	<u>Weightage in points</u>
Pre-Primary School (K.G.)	½ point
Primary School (I-V Classes)	1 point
Middle School (I-VIII Classes)	2 points

3.3.3 If we go by this criteria, the number of Z.E.Os required is given in the following table:

Number of Zonal Education Officers Required

<u>District</u>	<u>No. of Schools</u>			<u>Points</u>	<u>No. of Z.E.Os</u>
	<u>Pre-Middle</u>	<u>Primary</u>	<u>Pre-Primary</u>		
<u>1</u>	<u>2</u>	<u>3</u>	<u>4</u>	<u>5</u>	<u>6</u>
North	8	34	26	63	2
South	15	89	5	122	3
East	12	121	64	177	4
West	13	90	5	119	3
Total	48	334	100	481	12

3.3.4 So far the ministerial and lower staff is concerned, each Z.E.O should be provided with one post of LDC/Typist and one post of Peon. So the total number of staff required for Z.E.Os offices are:

Z.E.Os	-	12
L.D.Cs	-	12
Peons	-	12

3.3.5 Zonal Education Officers should be preferably located within the area of their jurisdiction. Area of the Zone should be contiguous one.

3.4 School Complexes

3.4.1 The existing experiment of having school complex at only primary level should be extended upto Higher Secondary level. The subject-supervision should be the responsibility of the subject teacher of the complex. Therefore, no post of subject specialist has been proposed at district or zonal levels. The complex organisers should also be given budgetary grants, for development of the resource centres for which the schools should be identified by the complex organisers.

3.5 Net Additional Staff Requirements

3.5.1 The net additional staff requirements upto the District level (including ZEOs) would be as under:

Additional Staff Requirements

Post	Scale of Pay	Number of Posts		
		Existing	Proposed	Balance + to be created to be up-graded or abolished
1	2	3	4	5
D.E.O.	300-1800 (Proposed)	4	4	-
Dy. D.E.O.	360-1440 (Proposed)	-	4	+4
Z.E.Os	660-1400 (Proposed)	-	12	+12
Project Officer	660-1400 (Proposed) 550-1100 (Existing)	4	4	-

1.	2. -	3.	4.	5.
Science & Trg. Supervisor	660-1400 (Proposed)	-	4	+4
Sports & Youth Welfare Officer	660-1400 (Proposed)	-	4	+4
Asstt. Education Officer	550-1100	10	-	+10
Head Asstt.	450-800	-	4	+4
Statistical Asstt.	410-700	-	4	+4
U. D. C.	410-700	3	-	-3
Accountant	410-700	-	4	+4
LDC/Typist	380-550	11	12	+1
Peons/Drivers	300-380	8	16	+8

3.5.2 Functions of office of the District
Education Officer:

Some of the functions of various branches of the D.E.O. office are suggested here. Additions and alterations can be made in these functions according to the local requirements:

a) Planning, Statistics & Monitoring Section

- School mapping
- Maintenance of information system
- Opening and upgrading of schools
- Recognition of non-government school
- Closure, amalgamation and shifting of schools
- School buildings/land cases
- Collection and compilation of statistics
- Preparation and monitoring of reports, medium and long term plans. Monitoring of elementary education
- Questions of legislature

- Organisation of seminars/conferences
- Academic matters like work experience, vocationalisation, 10+2 pattern
- Scrutiny of inspection proformae

b) Budget and Accounts Section

- Maintenance of Cash Book, acquittance rolls and other registers relating to payment
- Pay bills, arrear bills, T.A. bills, contingent bills
- Grant-in-aid cases
- Loans, financial assistance, scholarships and stipends to students
- Advances
- Audit objections
- Stores, stocks, forms and stationery
- Verification of service and issue of L.P.C.
- Expenditure, reconciliation and budget statements
- G.P. Fund cases
- Other related matters

c) Establishment Section

- All establishment matters in respect of gazetted/non-gazetted personnel
- Transfer of teachers
- Leave cases
- Pension cases
- Vigilance cases
- Tour programmes
- Appointment of substitute teachers
- Policy cases regarding establishment

d) General Section

- Text Books
- Secondary Board matters
- Examination
- Work relating to SC/STs/Linguistic minorities

Sub. National Systems Unit,
National Institute of Educational
 Administration
 New Delhi-110016

6924
 26.5.92.

- Audio Visual Education
- Vocation
- Unclassified items
- Inspection of schools

e) Non-formal Education Section

All work pertaining to non-formal education centres for children under elementary education and adults under adult education.

f) Science & Training Section

- Improvement of teaching of science education in all types of schools particularly at elementary stage through use of science kits.
- Helping of S.I.E. in planning and organisation of various types of in-service and pre-service training programmes for the District.

g) Sports & Youth Welfare Section

- Youth Welfare Programmes
- Organisation of Sports, games, tournaments
- N.C.C. & girl guides
- Physical education in schools
- Training of P.T. Is

3.6

Re-organisation of Directorate of Education

3.6.1 As already mentioned that the Directorate of Education is not only poorly staffed but also poorly organised. What is required is a strong, well built organisational unit which can function boldly, effectively and imaginatively so as to meet the challenges of educational transformation, improvement of standards and expansion of facilities. Accordingly, a proposal for reorganisation of the Directorate of Education has been worked out and is reflected in a chart given in the Annexure - III.

3.6.2 In the proposed set-up the Director of Education will be overall incharge of school education whereas higher and technical education would be under the direct control of the Education Secretary.

3.6.3 The Directorate of Education will consist of the following three important Wings:

1. Planning, Statistics & Budget ;
2. Educational Administration ; and
3. State Council of Educational Research & Training

3.6.4 All these three wings will be under the charge of an officer of the rank of Joint Director. However, the S.C.E.R.T. would not form part of Directorate but would be a semi-autonomous organisation. The Director of Education would also be its ex-officio Director.

3.6.5 The Directorate of Education will have six Divisions under the charge of an officer of the rank of Deputy Director of Education. These six Divisions will be grouped in two Wings to be headed by Joint Directors as shown below:

A. Joint Director of Education

(Plg., Budget & Coordination)

1. Planning, Statistics and Monitoring Division
2. Budget and Accounts Division

B. Joint Director of Education

(Educational Administration)

3. Non-formal Education Division
4. School Education Division
5. School Administration Division
6. Sports & Youth Welfare Division

3.6.6 The details of staff strength both at officer and lower staff levels as indicated in Annexure-III would require the following staff strength:

Staff Requirements of Proposed set-up of Directorate of Education

Post	Pay scale	Number of posts required
1	2	3
i) Director	1350-2400	1
ii) Joint Director	1200-2000	2
iii) Dy.Directors/ Sr.Accounts Officer	900-1800	6
iv) Asstt.Director/ Accounts Officer	610-1400	14
v) Office Superintendent/ Statistician/ Sr. Accountant	510-900	6
vi) Head Asstt/Sr.Sts. Assistants, Accountant	450-800	13
vii) UDC, Jr.Sts.Asstt. SAC	410-800	14
viii) LDC/Typists	380-550	18
ix) Driver/Head Peon	350-550	1
x) Head Peon/Driver	340-500	2
xi) Peons/Class IV	300-380	20
Total posts		97

3.6.7 Office of every sub-unit should be headed either by an official of the rank of superintendent or Head Assistant or UDC, i.e. Upper Division Clerk. Even the strength of the staff in an office should be given on the basis of certain norms i.e. full unit or half unit.

Full unit should invariably be headed by a section officer (Superintendent) or a UDC. There should be about four officials except Class IV employees in a sub-unit. In this structure PS to Director should also be of the rank of Assistant Director of Education. Similarly, Office Administration should be vested in A.D. (Office Admn.). It is expected that LDCs also work as typists.

3.6.8 The Assistant Director works in Planning, Statistics and Monitoring Division should preferably be a civil engineer who can be drawn on deputation from the State Public Works Department.

3.7 Functions of Various Units/Sub-Units

3.7.1 Planning, Statistics & Monitoring Division

This Division will consist of the following three Units:

- i) Planning & Monitoring;
- ii) Statistics & Survey; and
- iii) Works.

3.7.2 Planning and Monitoring Branch will deal with formulation and monitoring of annual, five year and long-term plans of the Education Department. It will also deal with schemes pertaining to creation of additional staff, issue of plan expenditure sanctions, review of progress of expenditure and physical targets, opening, upgrading and recognition of new schools etc.

3.7.3 It will also maintain liaison with Planning Commission, Union Ministry of Education, NIEPA, NCERT and other concerned agencies outside the State. It will maintain contacts with other States also to study the experience gained by them in implementation of Central Advisory Board of Education, Conference of Education Secretaries and Directors of Education.

It should also prepare evaluation reports of all the newly implemented schemes.

3.7.4 The main functions of the Statistics and Survey Branch will be:

- i) To collect and compile information from all types of educational institutions on prescribed forms;
- ii) To furnish information for various prescribed forms to the Ministry of Education;
- iii) To introduce and maintain a Management Information System;
- iv) To prepare Annual Reports and Statistical Digest of the Education Department;
- v) To deal with cases pertaining to supply of statistical information within and outside the State;
- vi) To deal with cases of publicity on educational development;
- vii) To keep upto-date information on physical targets and achievements of educational plans in the State;
- viii) To conduct regular and ad-hoc educational surveys and prepare reports;
- ix) To undertake work of school mapping and diagrammatic representation of educational statistics etc.

3.7.5 The Works Branch will deal with all matters relating to works needed for the Education Department including:

- i) Acquisition of land and rent cases;
- ii) Liaison in the PWD during construction and maintenance;
- iii) Regulation of use of land and building of the Department;
- iv) Construction and maintenance of school buildings with the support of local community; etc.

3.7.6 Budget and Accounts Division will comprise of two Branches:

- a) Scholarship Branch; and
- b) Budget and Accounts Branch.

3.7.7 Scholarships Branch will deal with all types of loans and scholarships being dealt with by the Education Department.

3.7.8 Budget and Accounts Branch will deal with following types of cases:

- i) Budget and accounts of the Department (plan and non-plan) as a whole;
- ii) Committed liability for the Department;
- iii) Economy and expenditure control;
- iv) Reconciliation of accounts and finalization of appropriation accounts of the Department;
- v) Grant-in-aid and utilisation by schools and voluntary educational organisation;

- vi) Audit of accounts of Government and aided schools;
- vii) Liaison with Audit parties from AGCR;
- viii) Disposal of internal audit observation;
- ix) Pension, leave salary recoveries of over payment, permanent advance advances and recoveries, GPF etc.

3.7.9 Non-Formal Education Division will have the following two Branches:

- 1) Adult Education Branch ; and
- ii) Non-Formal Primary Education Branch .

These two Branches will deal with all concerned cases pertaining to non-formal education, opening, maintenance and supervision of centres.

3.7.10 Sports & Youth Welfare Division will consist of two Branches:

- a) Sports & Youth Welfare Branch; and
- b) Physical Education, NCC and NSS Branch.

The main function of both these Branches would be:

- 1) Promotion of sports and physical education in schools;
- ii) Arranging supply of sports materials for schools;
- iii) Organisation of National School Games, Inter-school Tournaments, refresher courses and seminar on physical education;
- iv) Coordinating arrangements for Republic Day, Gandhi Jayanti, Scouts & Girls Guides, Red Cross, First Aid, etc.

- v) Grants-in-aid for promotion and development of physical education and play grounds;
- vi) Organisation of educational terms of students;
- vii) Sports Talent Search Scholarship Scheme;
- viii) Organisation of Sports Day and Coaching Camps for players and athletes in sports meets and tournaments;
- ix) Youth hostel.

3.7.11 School Education Division will have the following main functions:

- i) Cases pertaining to academic matters like vocationalisation, work experience, adoption of 10+2 pattern, science education;
- ii) Cases pertaining to SCERT and pre-service and in-service teacher training programme;
- iii) Programme for educational development of weaker sections of society and backward areas e.g. girls education, scheduled castes, scheduled tribes, physically handicapped etc.;
- iv) All matters relating to school education of linguistic minorities;
- v) Matters arising out of inspection of schools;
- vi) Coordination of inspection work in Districts;
- vii) Inspection of Higher Secondary Schools;
- viii) State and national awards;
- ix) Teachers' welfare.

3.7.12 School Administration Division will have three following main Branches:

- 1) Establishment Branch;
- ii) Store-Purchase Branch;
- iii) Office Administration & Coordination Branch.

3.7.13 Establishment Branch will deal with:

- All establishment matters relating to teaching and non-teaching staff of the Education Department which cannot be disposed off at the District level
- Taking over of private schools
- Clearance to fill up vacancies
- Deputation cases and service contracts
- Vigilance cases
- Court cases

3.7.14 Store-Purchase Branch will deal with cases pertaining to purchase of all types of material and equipment for schools and offices in consultation with the Budget and Accounts Branch.

3.7.15 Office Administration & Coordination Branch will deal with the following matters:

- 1) Central Registry including receipt and despatch;
- ii) Caretaking in the Directorate of Education;
- iii) Office administration & establishment matters;
- iv) Office form and stationery;

- v) Assembly and Parliament Questions;
- vi) All miscellaneous matters not covered under any other Branch, Public Relations, Statement in Press, etc.

3.8 State Council of Educational Research & Training

3.8.1 A State Council of Educational Research and Training be established as a registered society under a resolution of State Government to lay down broad guidelines and decided priorities for various programmes especially in the field of teacher education and to continuously review programmes of the Institute. The Council should meet at least once in a year and may consist of the following members:

- | | | |
|---|-------|------------------|
| 1. Minister of Education | _____ | Chairman |
| 2. Development Commissioner | | |
| 3. Education Secretary | | |
| 4. Director of Education | | |
| 5. Joint Director (SIE) | _____ | Member-Secretary |
| 6. Principal of Degree College | | |
| 7. Two nominees of the SIE | | |
| 8. Two eminent educationists to be nominated by the Ministry of Education | | |
| 9. Representatives of NIEPA & NCERT from Delhi | | |
| 10. Two Principals of Higher Secondary Schools | | |
| 11. Two teachers to be nominated by Director of Education | | |

The State Council of Education Research & Training may be supported by grants-in-aid by the State Government.

3.8.2 The State Institute of Education shall be under the control of SCERT and shall provide necessary secretarial assistance to the Council. Under the proposed structure of State Institute of Education, its set-up would be as under:

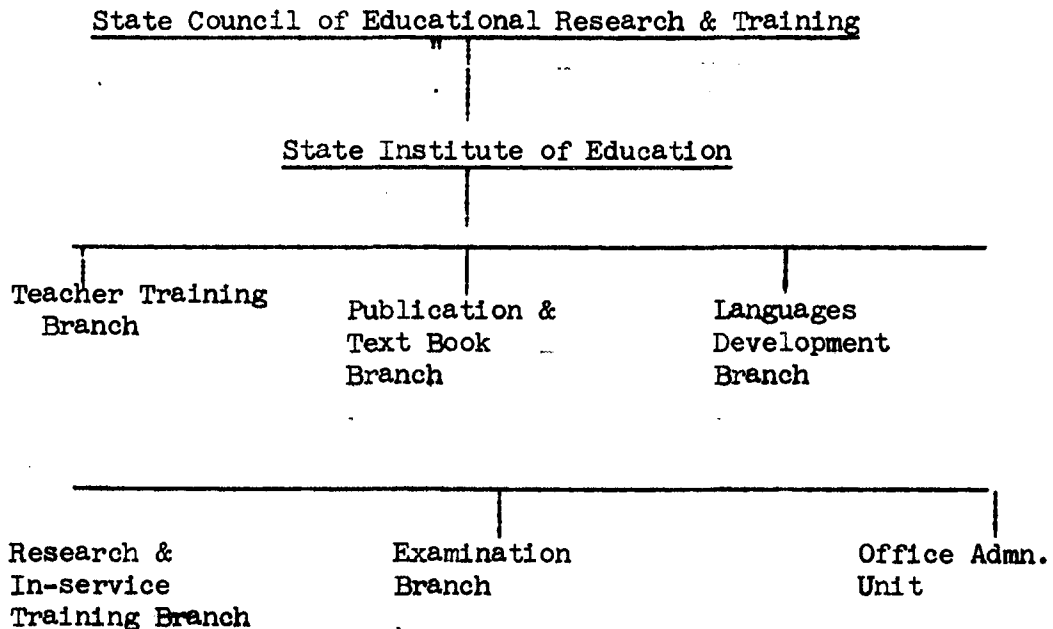

3.8.3 Each Branch except the office administration unit will be headed by an officer of the rank of Deputy Director of Education. The Incharge of SIE will be an officer of the rank of Joint Director. The Director of Education will be ex-officio Director of SIE.

3.8.4 The new set-up will have the following staffing pattern:

Staff Requirements of S.I.E.

Post	Grade	Number of posts
1. Joint Director	1200-2000	1
2. Deputy Directors	900-1800	5

Post	Grade	Number of posts
3. <u>Asstt. Directors</u> PGTs/Editor	660-1400	18
4. Instructors/ATWBs	550-1100	6
5. Superintendent	510-900	1
6. U.D.C.	410-700	2
7. L.D.C.	380-550	7
8. Class IV	300-380	8
	Total	<u>48</u>

3.8.5 An organogram giving various details of the S.I.E. is given in Annexure IV.

3.8.6 The main function of the State Institute of Education should be:

- i) Organisation of pre-service and in-service programmes of Teacher Education, with special emphasis on subject content training;
- ii) Preparation of guidebooks for teachers in various subjects;
- iii) Organisation of correspondence courses for teachers in various subjects in collaboration with NCERT and its Regional Colleges of Education;
- iv) Organisation of meetings, conferences, seminars, Lectures, Demonstrations improvement, including programmes to spread the understanding of the educational change;

- v) Undertaking of continuous follow-up, evaluation and research of various programmes undertaken by it and also various other projects, to be assigned from time to time by the Education Department;
- vi) Publication of Departmental Educational Journal, Reports, Studies etc. from time to time. It should also publish six Monthly Reports regularly for submission to the SCERT;
- vii) Organisation of short training courses in educational planning and administration in collaboration with NIEPA;
- viii) Conduct of Departmental examination.

For effectively carrying out the above function, the various units should be assigned the duties on the following lines:

a) Teacher Training Unit

- To conduct of regular pre-service teacher training courses
- To help in conduct of other in-service courses

b) Publication & Text Books Unit

- Preparation of text books;
- Printing of text books and other publications;
- Distribution of text books.

c) Languages Unit

- Development and preparation of local, regional and national languages and preparation of text books and teacher-guides for the same. It may cover languages like Tibetan, Lepcha, Limbo, Nepali, English & Hindi;

- Translation of text books/other publication in local languages;
- Propagation of Hindi language

d) Research & In-service Training Division

- Organisation of in-service/refresher courses for teachers;
- Preparation of teacher guides;
- Publication of Departmental Journal;
- Application and propagation of Educational Technology.

e) Examination Unit

- Conduct of all Departmental examinations.

f) Coordination Unit

- Office Administration;
- Coordination of activities;
- Organisation of meeting and conferences;
- All general and miscellaneous activities not covered by other units.

3.9 Additional Requirement of Posts

The above proposals for reorganisations of the Department would involve creation of the following additional posts:

Additional requirement of Posts

Post	Grade	Number of Posts			Total	Balance
		Existing	Proposed			
			Directo- rate	S.I.E.		
1	2	3	4	5	6	7
Director	1350-2400	1	1	-	1	-
Joint Director	1200-2000	1	2	1	3	+2
Dy. Director	900-1800	6	6	5	11	+5
Asstt Director/ Accounts Officer	660-1400	16	14	18	32	+16
Asstt. Edu. Officer	550-1100	16	-	6	6	-10
Office Supd/Sr Accountant/TBA	510-900	3	6	1	7	+4
N.A./Cashier/ Est.Asstt.	450-800	2	13	-	13	+11
UDC/Sts Asstt/ SAC	410-700	14	14	2	16	+2
LDC/Typists	380-550	29	18	7	25	-4
Driver/ Despatcher	350-550					
Head Peon/ Lib.Asstt.	340-500	7	3	-	3	-4
Peon Laskar	300-380	19	20	8	28	+9
Total		114	97	48	145	+31

3.10 Education Secretariat

3.10.1 As already mentioned, Education Department has already been bifurcated into a Directorate and a separate Secretariat Unit. The existence of secretariat usually helps in matters pertaining to

coordination and effective scrutiny of cases but this may also lead to delay. In view of the need to ensure proper coordination amongst all sub-sectors of education and to avoid delay following suggestions are made:

- a) The sector of Higher and Technical Education also should be under the direct charge of Education Secretary; and
- b) For sector of School Education, the Director should also be given appropriate ex-officio secretarial status and should be empowered under the rules of business of the Govt of Sikkim to dispose of all cases except cases which are required to be submitted to the Minister or Chief Minister or Cabinet, or which involve questions of policy or of coordination between Education Department and other Departments of Govt of Sikkim.

3.10.2 For this, the following set-up is proposed for the office of Education Secretary:

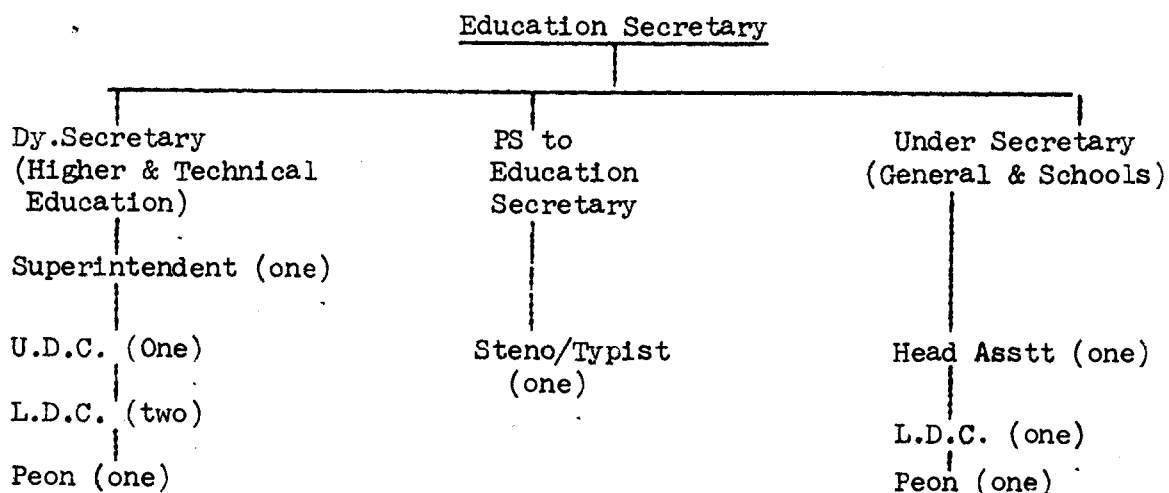

The above posts should be created in the usual scales of

3.11 General Suggestions

3.11.1 Following suggestions are also made for effective and smooth functioning of the above proposed reorganised structure:

- a) A Manual of Instructions should be prepared by the Government of Sikkim in which all the functions, responsibilities, business rules etc. of every unit and every staff member are clearly laid down;
- b) The Government of Sikkim should consider the question of enacting suitable legislation to regulate school education in the territory of the State. The law may provide inter-alia for appointment of a standing committee to advise the Government on matters pertaining to policy and for regulating recognition and aid to schools and conditions of service of employees of educational institutions;
- c) The officers should be given regular in-service training courses in educational planning and administration. The officer at lower level should also be given training in secretarial practice and office procedures;
- d) Norm for development and maintenance of educational services should be clearly laid down;
- e) Management Information System should be evolved so as to meet the information requirements of various levels of administration for various purposes.

2.3.2 It is suggested that working groups be set-up for all those areas for further action with the help, where necessary, of NIEPA Ministry of Education and other State Governments.

CHAPTER - III
(Points only)

General Recommendations:

These recommendations, and other, may include the following points:

- a) Universalisation of elementary education
- b) Adult education
- c) Each one teach one
- d) Language Issue (Medium of Instruction)
- e) Optimum utilization of language teachers
- f) Teacher training programme (Crash programme for clearing the backlog of untrained teachers)
- g) Undergraduate of I.T.I. to Polytechnic
- h) Vocationalisation and work experience

CHAPTER IVOTHER PRIORITY AREAS IN EDUCATION

4.1.1 The estimated child population in Sikkim and the enrolment in the age-group 6-14 years, according to the figures of Planning and Statistical Division of the Directorate of Education, Government of Sikkim for the year 1981 are 62757 and 54183 respectively. Since the number of children to be covered is not very large, the State can in the near future, perhaps claim to be the first State to achieve universalisation of elementary education, provided special efforts are made with adequate emphasis on certain major areas as discussed in the succeeding paragraphs.

4.1.2 There are about 700 unqualified/untrained teachers in the primary schools of the State. Most of them are non-matriculates appointed after 1975-76. No training programme appears to have been taken up, as done earlier prior to 1975, for removal of the academic/training deficiencies of the unqualified teachers.

4.1.3 The lack of proper academic/training qualification on the part of primary teachers in primary schools is a serious handicap in improving the standards of education in the State. It is, therefore, essential that in future only qualified teachers are appointed and further, the existing teachers are given immediately suitable full-time training programmes of 3 to 4 months duration.

4.1.4 It is recommended that a crash programme may be organised for the training of unqualified/untrained teachers of primary schools by the Teacher's Training Institute, Gangtok with the

help of the N.C.E.R.T. In view of the urgency of the matter it is recommended that the proposed training programmes may be organised in the ensuing winter break in December 1981 - January 1982 in Gangtok and other places. The Department of Education, Sikkim has expressed its willingness to depute about half of the contingent of unqualified teachers for training during the ensuing December/January break. The remaining half can be covered during the next winter break i.e. December 1982 - January 1983. The Department has also expressed its willingness to extend the vacation from 8 weeks to 3 months for the purpose of the training of teachers, if necessary.

4.1.5 The estimated district-wise child population and stage-wise enrolments figures for 1981 are as follows:

District	<u>Child Population</u>			<u>Enrolment</u>				
	<u>6 - 11</u>		<u>Total</u>	<u>11 - 14</u>		<u>Primary</u>		<u>Middle</u>
	<u>Boys</u>	<u>Girls</u>		<u>Boys</u>	<u>Girls</u>	<u>Total</u>		
North	1663	1642	3305	905	974	1959	3130	576
South	4714	4684	9428	2810	2780	5590	11296	1927
East	8713	8602	17315	5106	5106	10267	20102	4347
West	4705	4644	9349	2787	2757	5544	10743	2062
Total	19825	19572	39397	11743	11617	23360	45271	8912

4.1.6 The gross enrolment ratio for 6-11 years age group is reported to be 123% and that for 11-14 years age-group 27.3%. Obviously there is underage and overage enrolment of the children to a very large extent in the primary stage and also a large scale of drop-outs in different classes particularly at the middle stage.

There is also severe regional imbalance in the enrolment, with the North district lagging behind.

4.1.7 It is, therefore, necessary that new primary schools are opened in tribal areas and remote areas.

4.1.8 The opening of new primary/middle schools in the Sixth Plan may be done on school mapping basis. About only 64.34% of the rural population of Sikkim is being served by Primary school facilities within a radius of one kilometre as against 92.82% on All India basis. Similarly, as against 78.83% on All India basis, only about 42.30% of the rural population is being served by middle schooling facilities within a radius of 3 kilometre. Being a hilly terrain, the distance criteria also needs to be relaxed for school mapping purposes.

4.1.9 The enrolment in different classes is rapidly increasing, as a result of the several concessions of free education, subsidy to textbooks etc. For the retention of the children, it is necessary that adequate physical facilities e.g. school buildings, furniture and equipment etc. are provided. In view of the climatic conditions, the provision of proper school buildings needs to be given priority in the Sixth Plan programme.

4.1.10 According to an estimate of the Department of Education, Sikkim requires about 200 additional class rooms with adequate furniture to accommodate about 8000 additional children in the schools during 1981-82.

4.1.11 In the remote and inaccessible areas, it is essential to provide hostel facilities so that the students are not required to travel long distances for reaching the schools.

4.1.12 For the benefit of SC/ST students, it will be advisable to open residential Ashram schools under the schemes approved by the Government of India.

4.1.13 The medium of instruction in the schools is English which is also the official language of the State. According to the three-language formula in vogue in the State of Sikkim, the students are required to study English, Hindi and any one language; lepha/limbu/Nepali/Tibetan, as the third language in Class I-VIII.

4.1.14 It is noted that to provide facility for teaching of the several languages, the primary schools are provided with several language teachers. It is also observed that even in this arrangement, there is no facility, at the lower primary stage, for imparting instruction through the local cultural language viz. Lepcha, Limbu etc. Considering the restraint of resources of the State, which provide for primary teachers both in the Government and private schools, it is desirable that teacher utilisation is rationalised to the extent possible. It is also suggested that Lepcha and Limbu may be provided as a medium of instruction upto classes 1-3 in the new primary schools which are opened in the tribal areas wherever there is concentration of Lepcha and Limbu speaking population. This measure will increase the enrolment of children of these tribal areas in the new schools and also help reducing the drop-out rate. To ensure a smooth transition at the higher primary stage, these children will, however, be taught both in English and Hindi as languages from class I besides Lepcha and Limbu, as the case may be.

4.1.15 It is felt that if due attention is given in these major areas, the State of Sikkim would be able to achieve universalisation of elementary education as envisaged in the Sixth Five-Year Plan.

4.2 VOCATIONALISATION OF HIGHER SECONDARY EDUCATION

4.2.1 It is felt that the topography of the State of Sikkim is such that there is a tremendous scope for introduction of vocational courses at the higher secondary stage.

4.2.2 Only the following vocational courses have been recently introduced in one of the higher secondary schools, namely, T.N. Higher Secondary School, Gangtok from the academic session 1981-82:

1. Office Management and Secretarial Practice
2. Accountancy and Auditing
3. Typewriting (English)

Despite the fact that a sum of about Rs.1½ lakhs was sanctioned by the Government of India for introduction of vocational courses during 1978-79, the money unfortunately could not be utilised.

4.2.3 The Study Team thinks that the following vocational courses should have considerable potential in the near future:

1. Courses related to forestry
2. Courses related to chemical industry
3. Courses related to wool-base carpet weaving
4. Horticulture base courses in special crops such as tea and cardamom

These and other vocational courses may be considered by the Directorate of Education for being introduced in the higher secondary schools of Sikkim after conducting a proper survey of the available facilities and the demand in the four districts of the State.

4.3 Technical Institutions

4.3.1 At present there is only one Industrial Training Institute in the State of Sikkim. It may be advisable to open a few polytechnics and some additional Industrial Training Institutes in the State. The training in the polytechnics and ITIs will enable the students to branch off into various kinds of trades and also help them to undertake jobs or self-employment without pursuing college studies.

4.4 CENTRES FOR ADVANCED TRAINING

4.4.1 In view of the special location of Sikkim in the Himalayas it is thought that it is ideally suited for specialised advanced studies of different kinds. It is, therefore, recommended that the Government of India may set up in Sikkim some specialised institutes of national level for advanced studies. A few of the areas in which the Centres for Advanced Studies can be set up are as follows:

- (1) Centre for Advance Studies in High Altitude and Natural Preserves -

There are several Universities which are located in the Himalayan range and they can take advantage of the proposed centre for advance studies and training in this field.

- (2) Advance Centre for Study on Tropical Forest
- (3) Centre on Cardimomology - it can possibly serve as a laboratory of the IARI
- (4) Centre for Advance Studies in Tibetology

4.4.2 The above centres for advance studies should be national institutes and should be available for use by the whole of the country rather than being limited to the State of Sikkim.

4.5 EACH ONE TEACH ONE PROJECT

4.5.1 The Study Team is happy to note that a project entitled 'Each One Teach One' has been launched this year in the State by the Governor of Sikkim - Shri Homi J.H. Taleyarkhan.

4.5.2 At present the percentage of literacy in Sikkim is 34 according to the 1981 Census, as against the overall literacy rate of 36 in India. It is remarkable that while the rate of literacy was only 18 in Sikkim in 1975, it has almost been doubled during the last decade. 'Each One Teach One' Project will give further impetus to the programme of removing illiteracy. It is envisaged under the project that it is responsibility of about one lakh persons who are already literate in the State to lend their support to make the remaining about 2 lakh illiterate persons also literate. The 'Each One Teach One' Project should, therefore, be able to make a dent in removing illiteracy in the State particularly because of the deep interest that is being taken at the highest level. The project visualises involvement of the students from Class VIII onwards, besides involvement of all literate adults of the community. All Government departments and non-government voluntary organisations have also been requested to lend their support to the project. The Study Team fully commends the launching of the project and hopes that it will bear the desired fruits.

4.6 NON-FORMAL EDUCATION

4.6.1 The State Government proposes to start during the year a separate State-sponsored scheme of non-formal education for the age-group 6-16 who are out-of-school.

4.6.2 It may be advisable to have one Assistant Director specifically in charge of non-formal primary education in the State. The existing Assistant Director (Adult Education) will continue to deal with the adult education. In view of the increased stress on adult education in the coming years, the existing Assistant Director will be fully pre-occupied with the adult education programmes. And, therefore, it is recommended that the State may have a separate Assistant Director to look after the non-formal education programmes for children.

CHAPTER VCONCLUSION

5.1.1 The Study Team went into the problem of organisation in detail and felt that an in-depth analysis of the educational system in Sikkim is required in order to make the recommendations effective and useful. It went into the general and educational scenario in Sikkim and then examined the organisational structure of the Directorate of Education against the background of these scenarios which then gave suggestions for its functional and structural reorganisation. It also found the tremendous potentialities in the educational system of Sikkim for further development in the right lines, while considering the priority areas of education.

5.1.2 Besides the reorganisation of the Directorate of Education, the Study Team recommended a number of measures for the development of the educational system in Sikkim like crash programme for training of unqualified teachers, special drive for construction of school buildings and hostels, effective utilisation of the existing teachers, expansion of vocationalisation and setting up of Centres of Advanced Studies in disciplines which would be of relevance to the educational development of the State. One particular recommendation is the setting up of a State Council of Education to give direction and guidance to the State Institute of Education to enable it to play a more effective role in development of education in the State.

5.1.3 The Study Team would like to thank the Governor of Sikkim, the Education Minister, the Education Secretary and the Directorate

of Education and others for the help they have rendered in their work. The members of the team were given opportunities to study schools, adult education centres and other educational institutions at first hand, which enabled them to make their own independent assessment of the situation obtaining in the State. They had open discussions with teachers, officials and various non-officials associated with the educational system at Sikkim from various levels. Such discussions enabled the team to have a knowledge of the actual working of the system, particularly at grass root level.

5.1.4 Lastly, the Study Team would like to place on record the excellent hospitality extended to them by the Government of Sikkim during their visit of Sikkim from 20th to 27th June, 1981.

ANNEXURE I

A. Authorities with whom discussions were held by the Study Team during its visit to Sikkim

1. Shri Hari J.H. Teleyarkhan, Governor, Sikkim
2. Shri Sanchaman Limboo, Education Minister, Sikkim
3. Shri M.P. Pradhan, Chief Secretary, Sikkim
4. Shri M.M. Rassaily, Education Secretary, Sikkim
5. Shri R. Narayanan, Development Commissioner, Sikkim
6. Shri M.K. Sherale, Finance Secretary, Sikkim
7. Shri Madhu Sudan Singh, Director of Education, Sikkim
8. Shri D.C. Agnihotri, Deputy Director Education (Planning and Statistics), Sikkim
9. Shri A.C. Singh, Statistical Officer (Education), Sikkim
10. Shri J. Bari, Assistant Director (Sports), Sikkim
11. Shri K.L. Bamola, Deputy level Director of Education, Sikkim
12. Shri S.N. Lal Gupta, Zonal Deputy Director of Education, Sikkim
13. Shri C. Pradhan, DEO, Sikkim
14. Shri P.B. Khatri, DEO, Sikkim
15. Shri D.D. Sen Gupta, DEO, Sikkim
16. Shri K. Stephen, DEO, Sikkim
17. Shri T. Gyatso, Deputy Director (Adult Education), Sikkim
18. Shri B.R. Bhattacharyya, Assistant Director (Adult Education), Sikkim
19. Miss K.T. Lepclia, Assistant Director (S.I.E.), Sikkim
20. Shri B.K. Sharma, Assistant Director Voc.Education Officer, Sikkim
21. Shri R.P. Tripatty, District Voc.Education Officer, Sikkim
22. Shri C.N. Sharma, O.S.D.(Education), Sikkim
23. Shri Dhinesh S., A.D.E.(Acd), Sikkim
24. All principals of Higher Secondary Schools and selected heads of High and Senior High Schools

(A number of other officers including Assistant Education Officers were also met in a general meeting and individually also)

B. Institutions visited

1. Government High School, Deolali
2. Government Central School, Deolali
3. P.N. Girls School, Gangtok
4. T.N. High School, Gangtok
5. Suchary School, Gangtok
6. Adult Education Centres at Deolali
7. Cottage Industries Training Centre, Gangtok
8. State Institute of Education, Gangtok
9. Sikkim Research Institute of Tivetology, Gangtok
10. Higher Secondary School, Pelling

ORGANOGRAM OF DIRECTORATE OF EDUCATION OF SIKKIM (1981 - Onw) Existing

Education Minister

Education Secretary

Director of Education

Joint Director of Education

<u>Pay Scale</u>	<u>No. of Posts</u>
1350-2400	1
1200-2000	1
900-1800	8
660-1400	20
550-1100	31
510-900	3
450-800	2
410-700	17
380-550	42
350-550	1
340-500	7
300-380	30

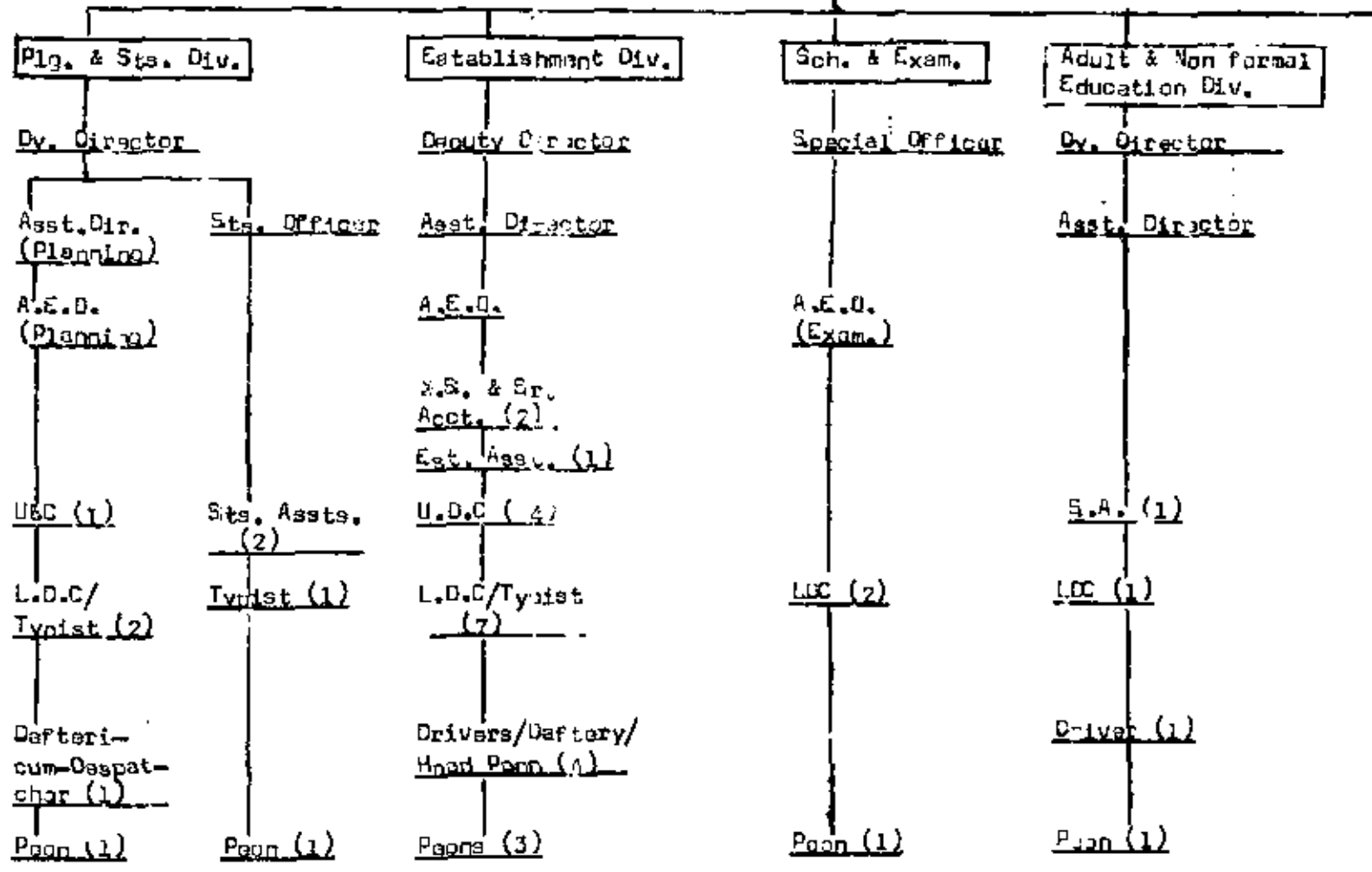

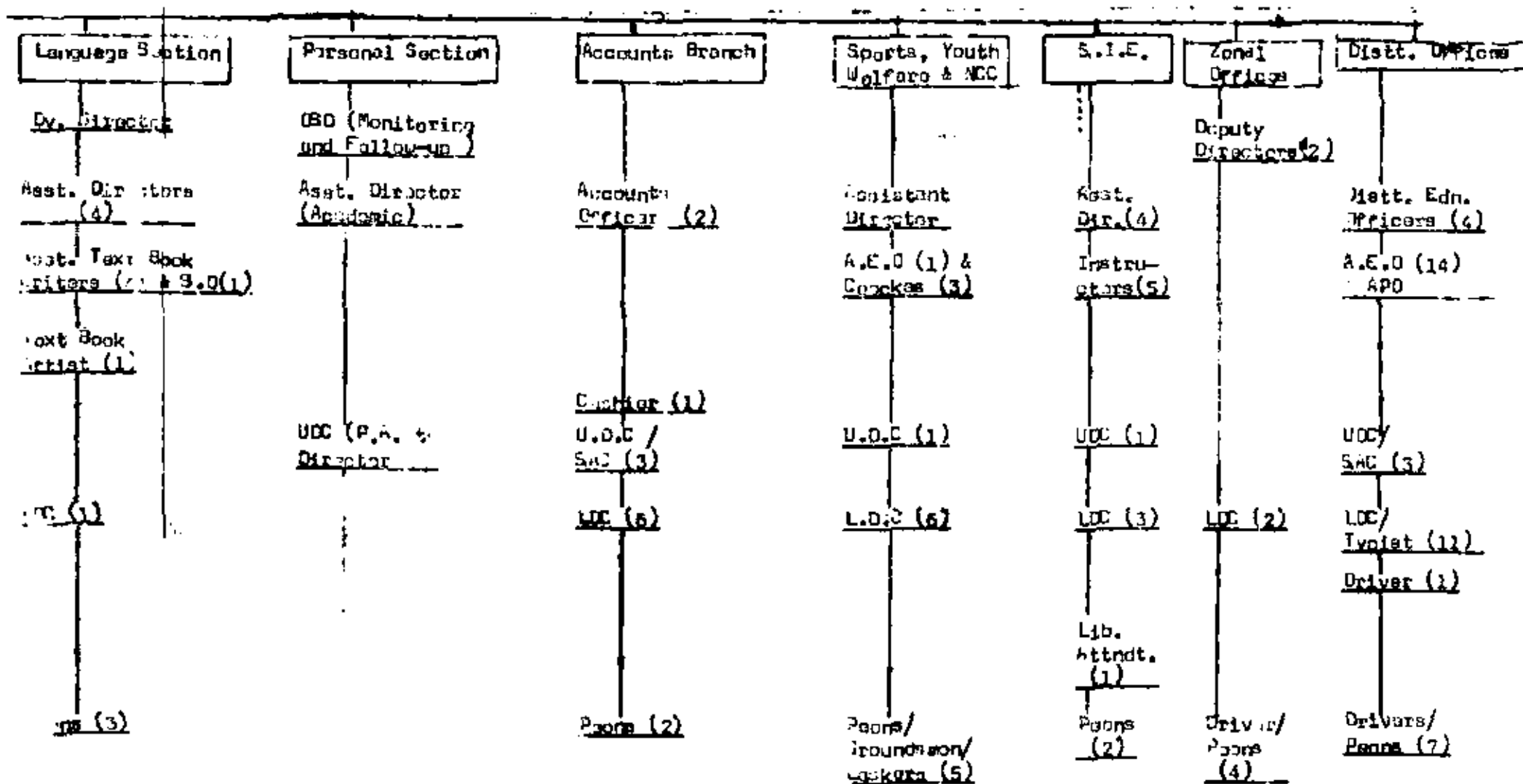

PROPOSED ORGANOGAM OF DIRECTORATE OF EDUCATION OF SIKKIM

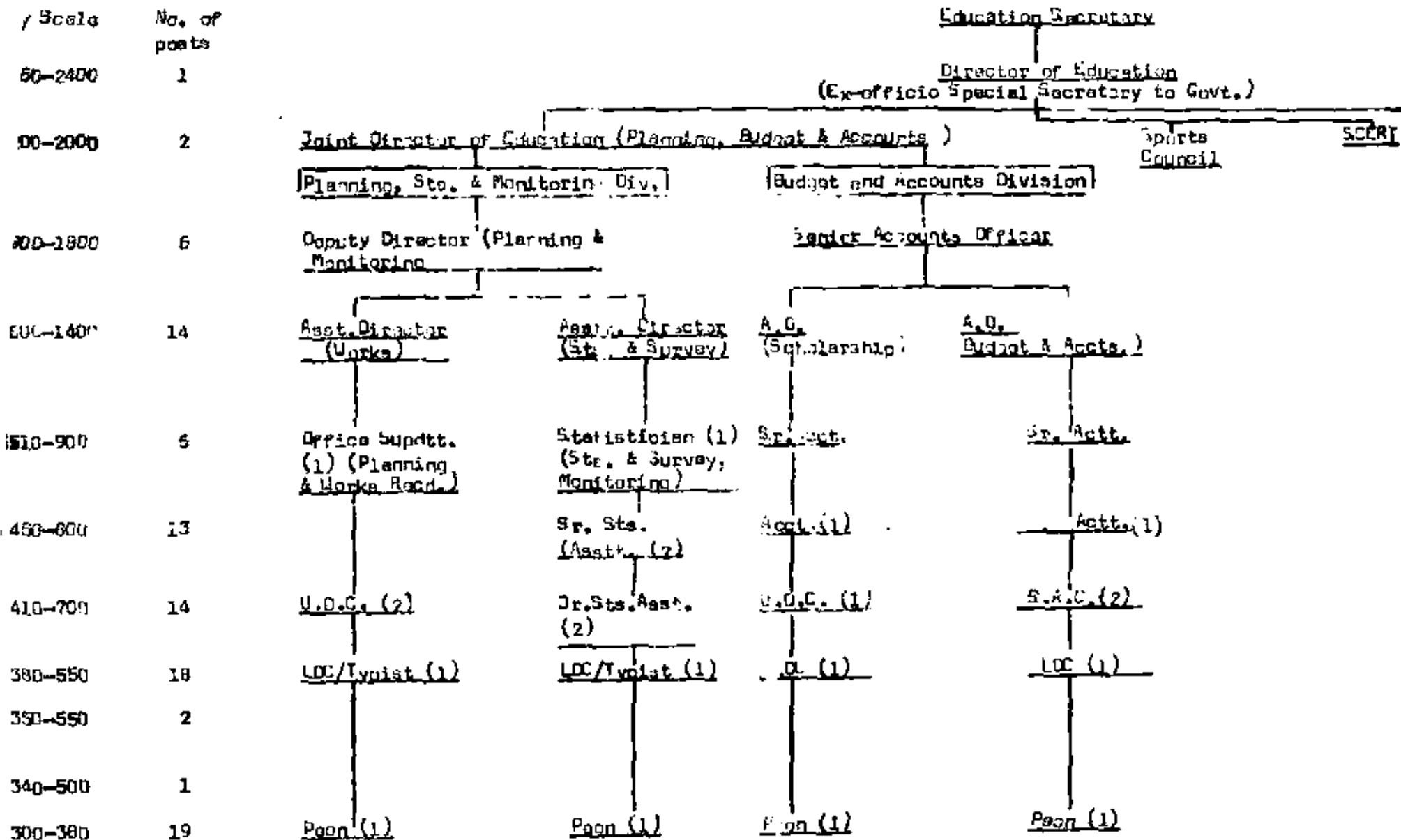

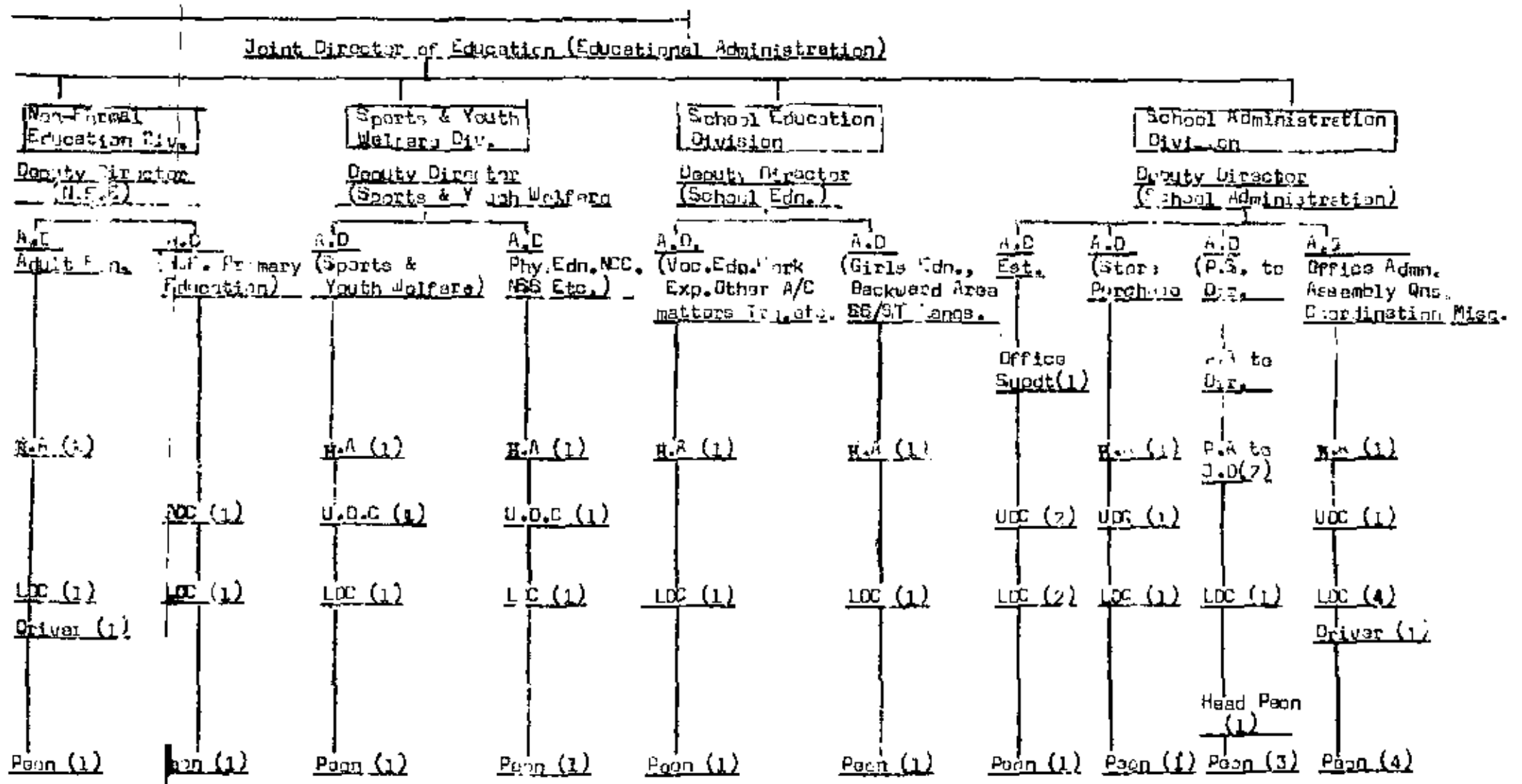

ANNEXURE IV

STATE COUNCIL OF EDUCATIONAL RESEARCH & TRAINING

State Institute of Education

(Proposed set-up)

Pay Scale
200-2000

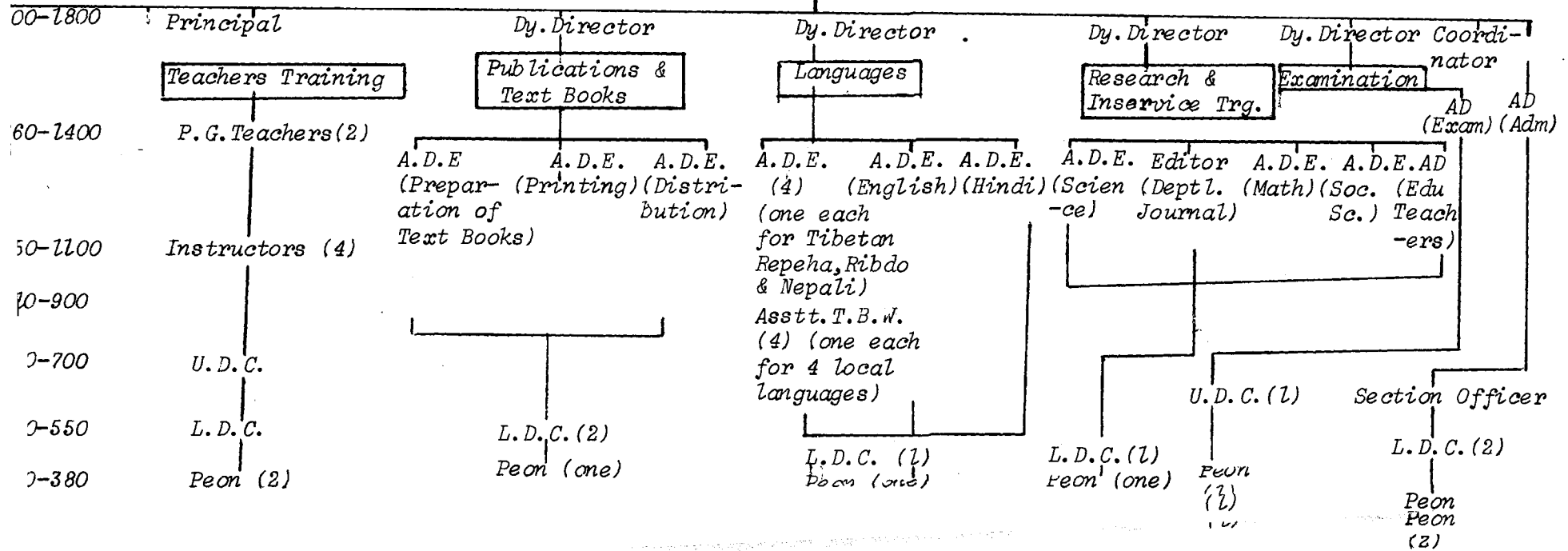

State Institute of Education (Existing set-up)

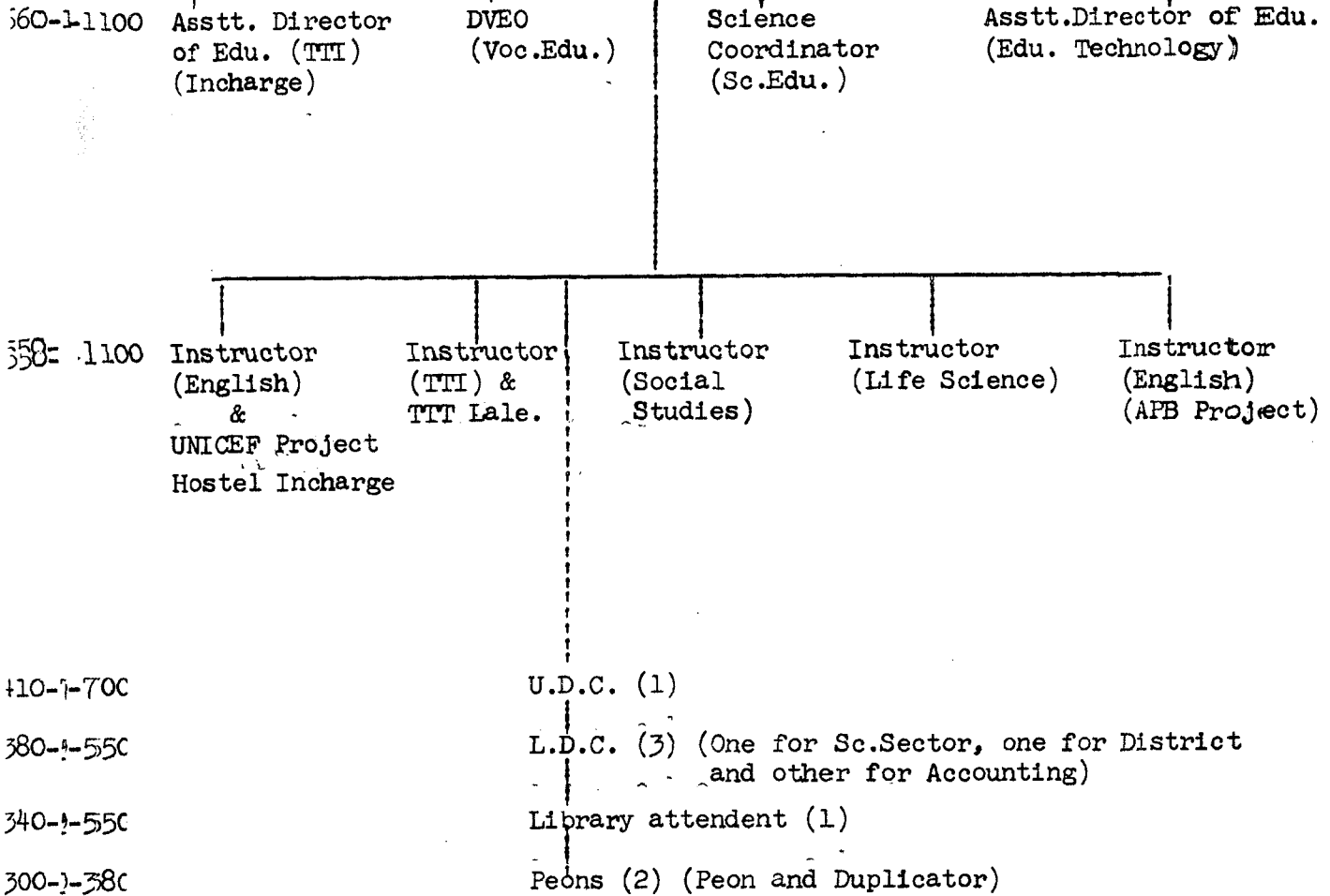

Language Section

900-1800

Dy. Director
 (Inp. Sup. of language,
 Sup. of Text Books, Assect. & Trg.
 & Transfer of Language Trs.)

650-1400

Text Book Officer
 (Tibetan)

Text Book Officers
 (Lepcha)

Text Book Offr.
 (Limbo)

Text Book Or.
 (Nepali)

550-1100

Asstt. Text Book Writer
 (Tibetan)

Asstt. T.B. Writers
 Text Book Artist (Lepcha)
 (One)

Asstt. T.B. Writer
 (Limbo)

Asstt. T.B. S
 Writer (Nepali) Bod

450-900

30-550

L.D.C. (One)

20-380

Peons (Three)

NIEPA DC



D06924